

OPERATION MANUAL

AC VOLTMETER

MODEL 1633B/1653B

KIKUSUI ELECTRONICS CORPORATION

79.7.28

793679

Power Requirements of this Product

Power requirements of this product have been changed and the relevant sections of the Operation Manual should be revised accordingly.

(Revision should be applied to items indicated by a check mark)

Input voltage

The input voltage of this product is _____ VAC,
and the voltage range is _____ to _____ VAC. Use the product within this range only.

Input fuse

The rating of this product's input fuse is _____ A, _____ VAC, and _____.

WARNING

- To avoid electrical shock, always disconnect the AC power cable or turn off the switch on the switchboard before attempting to check or replace the fuse.
- Use a fuse element having a shape, rating, and characteristics suitable for this product. The use of a fuse with a different rating or one that short circuits the fuse holder may result in fire, electric shock, or irreparable damage.

AC power cable

The product is provided with AC power cables described below. If the cable has no power plug, attach a power plug or crimp-style terminals to the cable in accordance with the wire colors specified in the drawing.

WARNING

- The attachment of a power plug or crimp-style terminals must be carried out by qualified personnel.

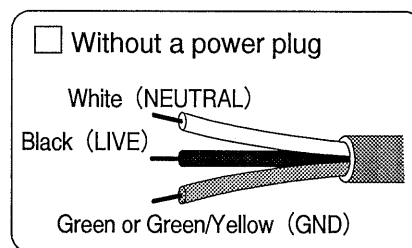

TABLE OF CONTENTS

	<u>PAGE</u>
1. GENERAL	1
2. SPECIFICATIONS	2
3. OPERATING INSTRUCTIONS	5
3.1 Explanation of Front and Rear Panels	5
3.2 Preparations for Measurement	9
3.3 AC Voltage Measurement	10
3.4 AC Current Measurement	12
3.5 Use as an Output Meter	13
3.6 Waveform Errors	13
3.7 How to Use the Decibel Charts	14
4. OPERATING PRINCIPLE	19
4.1 Input Circuit	19
4.2 Preamplifier	20
4.3 Meter Driver	20
4.4 Output Circuit	21
4.5 Power Supply	21
5. MAINTENANCE	22
5.1 Inspection of Internal Components	22
5.2 Adjustment and Calibration	23
5.3 Troubleshooting	24
* Decibel conversion chart (Fig. 3-3)	
* Decibel addition chart (Fig. 3-4)	

793630

1. GENERAL

Kikusui Model 1633B/1653B AC Voltmeter is high sensitivity meter which indicates the mean value of the measured voltage. With all circuits in solid state electronics, this voltmeter is compact, light, and consume less power.

The voltmeter consists of an impedance converter with high input impedance, a voltage dividers (attenuators), a meter driver circuit, an output circuit, and a constant voltage power supply.

The measuring range of Model 1633B is 30 μ V ~ 100 V rms (-90 ~ +42 dBm, -90 ~ +40 dBV) and that of Model 1653B is 50 μ V ~ 150 V rms (-90 ~ +46 dBm, -90 ~ +44 dBV), divided into 12 sub-ranges in 10-dB steps. The scales are graduated in equal divisions in r.m.s. value of sinusoidal wave. The measuring frequency range is 5 Hz ~ 1 MHz.

The output terminal of Model 1633B provides an AC output voltage of about 1 V for the full scale and that of Model 1653B provides an AC output voltage of about 1.5 V for the full scale. Therefore, the voltmeter can be used also as monitor or preamplifier.

2. SPECIFICATIONS

Nomenclature: AC Voltmeter

Model No.: 1633B (1653B)

Power requirements: 100 V, 50/60 Hz AC, approx. 4 VA
(convertible to 110/117/220/230/240 V
by internal transformer tap change)

Dimensions: 140 (W) x 200 (H) x 205 (D) mm
(5.51(W) x 7.87(H) x 8.07(D) in.)
(Maximum dimensions): 143 (W) x 215 (H) x 235 (D) mm
(5.16(W) x 8.46(H) x 9.25(D) in.)

Weight: Approx. 3 kg (6.6 lbs)

Indicating meter: Scale length approx. 105 mm (4.13 in.), 2 colors,
full scale 1 mA

Scales:
RMS scale (black) rms value of sinusoidal wave
dBm scale (red) with reference to 1 mW, 600 Ω
dBv scale (red) with reference to 1.0 V, 0 dB

Input

Input terminal: distance 19 mm (3/4 in.)

Input resistance: 10 M Ω for each range

Input capacitance:
300 μ V ~ 100 mV (500 μ V ~ 150 mV for 1653B) range ... 40 pF or less
300 mV ~ 100 V (500 mV ~ 150 V for 1653B) range 25 pF or less

Maximum input voltage:
300 μ V ~ 100 mV range (500 μ V ~ 150 mV range for 1653B):
AC component 50 V rms
±70 V peak

300 mV 100 V range (for 1633B only)

AC component 100 V rms
±150 V peak

500 mV 150 V range (for 1653B only)

AC component 150 V rms
±250 V peak

DC component (for all ranges) ±400 V

Ranges: 12 ranges

RMS scale: 300 μV/1/3/10/30/100/300 mV
1/3/10/30/100 V

(for 1653B)

500 μV/1.5/5/15/50/150/500 mV
1.5/5/15/50/150 V

dBm and dBv scales: -70/-60/-50/-40/-30/-20/-10/0/10/20/30/40 dB

Accuracy: ±3% FS, at 1 kHz

Stability: Better than 0.5% FS for ±10% line voltage
variation

Temperature coefficient: 0.05%/°C, at 1 kHz (typical value)

Frequency characteristics:

5 Hz ~ 1 MHz ±10% (with reference to 1 kHz)
10 Hz ~ 1 MHz ±5% (with reference to 1 kHz)
20 Hz ~ 200 kHz ±3% (with reference to 1 kHz)

Noise: Less than 4% with input shorted

Output

Output terminal: 5-WAY terminal, distance 19 mm (3/4 in.)

Output voltage: About 1 V rms (1.5 V rms for 1653B) at
full scale, at 1 kHz

Distortion factor: Less than 3% at full scale, at 1 kHz

Frequency characteristics: +1 ~ -3 dB for 7 Hz ~ 250 kHz
(with 10 M Ω , 50 pF connected)

Accessories: Operation manual 1

793684

3. OPERATING INSTRUCTIONS

3.1 Explanation of Front and Rear Panels

o Front Panel

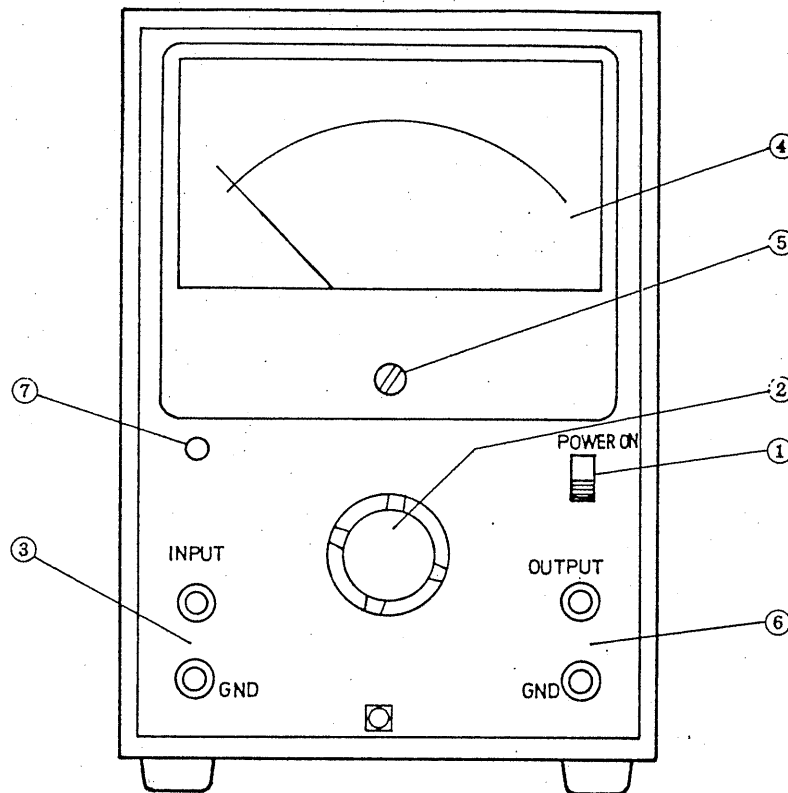

Fig. 3-1

(1) POWER switch:

When the switch is thrown to the POWER ON position (upper position), the meter power is turned on and the POWER pilot lamp (7) lights.

The meter pointer may deflect irregularly for about 10 seconds after the power is turned on but this is transient and not an abnormal indication.

(2) Range Switch:

The knob located in the center of front panel. The figures indicate the full scale voltages (black) or dB values (red). The ranges are higher as this switch is turned clockwise. In order to prevent overvoltages to the voltmeter, start with the highest range and gradually turn to lower ranges observing the meter pointer deflection.

(3) INPUT terminal:

The terminal to which the signal to be measured is applied. Connection can be conveniently made with a standard 2-pin banana plug (distance $3/4'' = 19$ mm).

Connection can be made with a banana plug, a spade lug, an alligator clip, a 2-mm (0.079 in.) tip or a wire of smaller than 2-mm (0.079 in.).

GND terminal is electrically connected to the meter panel and chassis.

(4) Indicating meter:

The indicating meter has four scales, from top to bottom, as explained in the following.

Meter scales of the 1633B

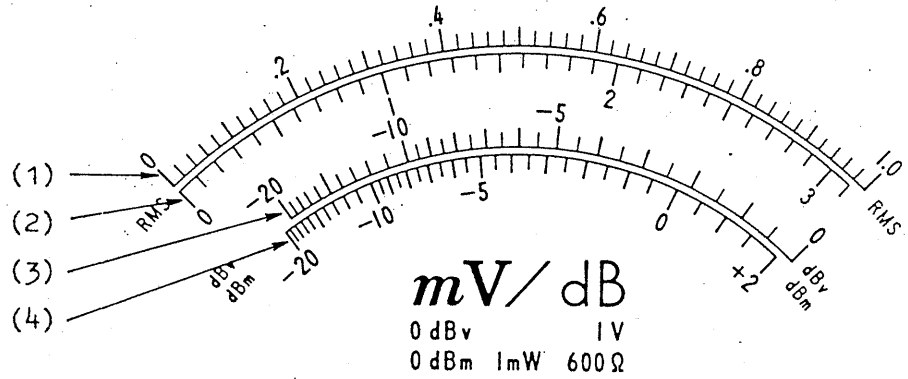

- (1) "1" scale: For 1/10/100 mV and 1/10/100 V ranges.
- (2) "3" scale: For 300 μV/3/30/300 mV and 3/30 V ranges.
- (3) "dBv" scale: For measurement in dBv value with reference to 1.0 V as 0 dB. Total range of -70 ~ 40 dB (12 sub-ranges) is covered with single scale.
- (4) "dBm" scale: For measurement in dBm value with reference to 1 mW, 600 Ω. Total range of -70 ~ 40 dB (12 sub-ranges) is covered with single scale.

Meter scales of the 1653B

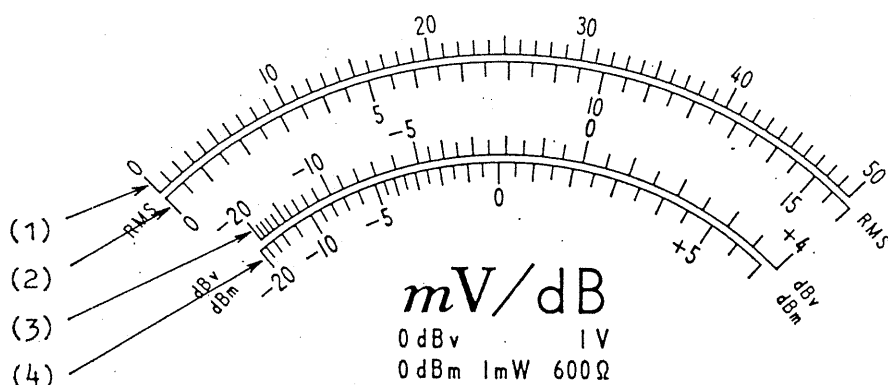

(1) "50" scale: For 500 μ V/5/50/500 mV and 5/50 V ranges.

(2) "15" scale: For 1.5/15/150 mV and 1.5/15/150 V ranges

(3) "dBv" range: For measurement in dBv value with reference to 1.0 V as 0 dB. Total ranges of -70 ~ 40 dB (12 sub-ranges) is covered with single scale.

(4) "dBm" scale: For measurement in dBm value with reference to 1 mW, 600 Ω . Total range of -70 ~ 40 dB (12 sub-ranges) is covered with single scale.

(5) ZERO adjustment:

For mechanical ZERO adjustment of indicating meter. This adjustment must be made with the voltmeter power turned off. (Allow more than 5 minutes after turning off the power so that the pointer settles in a position close to the zero scale position.)

(6) OUTPUT terminal:

The OUTPUT terminal used when the voltmeter is operated as an amplifier. Connection can be most conveniently made with a 2-pin banana plug, though it can also be made with a banana plug, a spade lug, an alligator clip, 2-mm (0.079 in.) tip or a wire of 2-mm (0.079 in.) or less.

(7) POWER PILOT lamp:

This lamp lights when the voltmeter power is on.

o Rear Panel

(8) Fuse holder:

Holds the fuse of the primary circuit of the power transformer. For fuse replacement, remove the cap by turning it counterclockwise (in the direction indicated by the arrow).

3.2 Preparations for Measurement

- (1) Turn OFF the POWER switch at the right-hand side on the front panel.
- (2) Check that the meter pointer is settled accurately at the zero scale position. If it is not, set it accurately in the zero position as explained in Item (5) "ZERO adjustment" of Sub-section 3.1 "Preparation for Measurement." (Refer to Fig. 3-1.) If the voltmeter power has been OFF, turn it and allow more than 5 minutes so that the meter pointer is settled in a position close to the zero scale position.

- (3) Connect the power cord to an AC power line outlet of 100 V (or other voltage to which the voltmeter has been converted), 50 or 60 Hz.
- (4) Set the RANGE switch in the highest voltage range (100 V or 150 V).
- (5) Turn ON the POWER switch. The POWER PILOT lamp will light indicating that the power is turned on. The meter pointer may deflect irregularly for about 10 seconds after the switch is turned ON (or OFF), but this is only transient and not an abnormal indication.
- (6) When the pointer is stabilized, the voltmeter is ready for measurement.

3.3 AC Voltage Measurement

- (1) When the measured signal level is low or the measured signal source impedance is high, the input line is susceptible to external noise. To guard against noise, use shielded wires or a coaxial cable depending on the noise frequency.

Note: For measurement at high sensitivity ranges, use shielded wires or a coaxial cable in order to prevent coupling through radiation from the indicating meter.

- (2) In order to prevent overvoltage to the voltmeter, start measuring with the highest range and gradually lower the range observing the pointer deflection.

(3) Use the "1.0" and "3" scales ("15" and "50" scales for the 1653B) of the indicating meter. The scale values are as shown in Table 3-1.

Table 3-1

Model	Range		Scale	Scale factor	Unit	Gain (dB)
1633B	300 μ V	-70 dB	3	x 100	μ V	70
	1 mV	-60 dB	1.0	x 1	mV	60
	3 mV	-50 dB	3	x 1	mV	50
	10 mV	-40 dB	1.0	x 10	mV	40
	30 mV	-30 dB	3	x 10	mV	30
	100 mV	-20 dB	1.0	x 100	mV	20
	300 mV	-10 dB	3	x 100	mV	10
	1 V	0 dB	1.0	x 1	V	0
	3 V	10 dB	3	x 1	V	-10
	10 V	20 dB	1.0	x 10	V	-20
	30 V	30 dB	3	x 10	V	-30
	100 V	40 dB	1.0	x 100	V	-40
1653B	500 μ V	-70 dB	50	x 10	μ V	70
	1.5 mV	-60 dB	15	x 0.1	mV	60
	5 mV	-50 dB	50	x 0.1	mV	50
	15 mV	-40 dB	15	x 1	mV	40
	50 mV	-30 dB	50	x 1	mV	30
	150 mV	-20 dB	15	x 10	mV	20
	500 mV	-10 dB	50	x 10	mV	10
	1.5 V	0 dB	15	x 0.1	V	0
	5 V	10 dB	50	x 0.1	V	-10
	15 V	20 dB	15	x 1	V	-20
	50 V	30 dB	50	x 1	V	-30
	150 V	40 dB	15	x 10	V	-40

- (4) To measure the input voltage in dBm value with reference to 1 mW 600 Ω , use the common dBm scale and determine the value as follows: The "0" position in the center position of the dBm scale represents the level of each range name. To determine the dBm value of the measured signal, add the dBm value of the range name to the dBm value indicated by the meter pointer.

Example 1: When the pointer indication is 2 (dBm) at the "30 dBm (30 V)" range, determine the signal level as follows:

$$2 + 30 = 32 \text{ dBm}$$

Example 2: When the pointer indication is 1 dBm at the "-20 dBm (100 mV)" range, determine the signal level as follows:

$$1 + (-20) = 1 - 20 = -19 \text{ dBm}$$

3.4 AC Current Measurement

To measure an AC current with this voltmeter, feed the current (I) through a non-inductive resistor of known resistance (R) and measure the voltage drop (E) developed across the resistor. The current can be determined as $I = E/R$. In this case, note that the "-" input terminal is connected to the ground.

Example: Measure the heater current of a vacuum tube (nominal 6.3 V, 0.3 A).

Assume that a non-inductive resistor of 0.1 Ω was connected as shown in Fig. 3-3 and the meter reading was 29 mV. The current can be determined as follows:

$$I = \frac{E}{R} = \frac{29 \times 10^{-3}}{0.1} = 290 \times 10^{-3} \text{ (A)} = 290 \text{ mA}$$

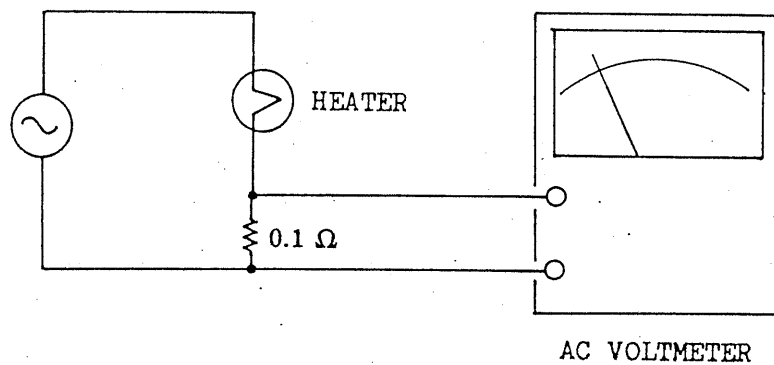

Fig. 3-2

3.5 Use as an Output Meter

Measuring the voltage (e) developed across a certain impedance (X), the apparent power (VA) in the impedance (X) can be determined as $VA = E^2/X$. Assuming that the impedance (X) is a pure resistance (R), the power (P) consumed in the resistance (R) is calculated as follows:

$$P = E^2/R$$

Since the meter scale is graduated in dBm value, the power can be directly read in dB value when the resistance is 600 Ω . By using the decibel conversion charts of Figs. 3-4 and 3-5, the power can be determined in dB value by adding the value obtained from Fig. 3-4 or 3-5, even when the load resistance is 1 Ω ~ 10 k Ω .

3.6 Waveform Errors

This voltmeter is a "mean-value indicating" voltmeter which indicates a value corresponding to the means value of the measured voltage. The meter scales are calibrated in the r.m.s. value of a sinusoidal wave. If the measured signal waveform

is distorted, errors are introduced and the voltmeter does not indicate the correct r.m.s. value. Rates of errors caused by waveform distortions are shown in Table 3-2.

Table 3-2

Measured voltage	r.m.s. value (%)	Meter indication (%)
Amplitude 100% fundamental wave	100	100
100% fundamental wave +10% 2nd harmonic wave	100.5	100
100% fundamental wave +20% 2nd harmonic wave	102	100 - 102
100% fundamental wave +50% 2nd harmonic wave	112	100 - 110
100% fundamental wave +10% 3rd harmonic wave	100.5	96 - 104
100% fundamental wave +20% 3rd harmonic wave	102	94 - 108
100% fundamental wave +50% 3rd harmonic wave	112	90 - 116

3.7 How to Use the Decibel Charts

(1) Decibel

Bel (B) is a unit of measure for comparing two power levels in terms of common logarithms with 10 as its base. Decibel is one-tenth of Bel (B) as indicated with affix "d" and its is expressed as follows:

$$dB = 10 \log_{10} \frac{P_2}{P_1}$$

In other words, the dB value indicates the ratio of power P_2 with respect to power P_1 in terms of common logarithms multiplied by a factor of 10.

When the impedance and other conditions are the same at the point where P_1 and P_2 exist, the power ratio can be expressed in terms of voltage ratio or current ratio as follows:

$$\text{dB} = 20 \log_{10} \frac{E_2}{E_1} \quad \text{or} \quad = 20 \log_{10} \frac{I_2}{I_1}$$

Though decibel initially was meant for representing the ratio of power levels, it since long ago has become to be used in a broader sense to indicate a ratio between two numbers in terms of common logarithms.

For example, when the input voltage of an amplifier is 10 mV and its output is 10 V, the gain is $10\text{V}/10\text{mV} = 1000$. In terms of decibel, the amplifier gain is expressed as follows:

$$\text{Gain} = 20 \log_{10} \frac{10 \text{ V}}{10\text{mV}} = 60 \text{ dB}$$

For a standard RF signal generator for example, its output voltage is given in terms of dB value with reference to 1 μV . When the output voltage is 10 mV, it is expressed in dB value as follows:

$$10 \text{ mV} = 20 \log_{10} \frac{10 \text{ mV}}{1 \mu\text{V}} = 80 \text{ dB}$$

When given in a dB value, the reference value or the 0 dB value should be indicated. In the case of the signal generator of the above example, the output voltage should be indicated as 10 mV = 80 dB (1 μV = 0 dB) with the 0 dB value given enclosed in parentheses.

(2) dBm, dBv

Term dBm means dB(mW). It represents a power ratio with reference to 1 mW as 0 dB. In general the term is for a case that the impedance of the power measuring point is 600 Ω . In other words, the term signifies dB (mW, 600 Ω).

When the power and impedance are specified as above, decibel can represent voltage and current as well as power. Term dBm is given with reference to the values as follows:

$$\begin{aligned} 0 \text{ dBm} &= 1 \text{ mW} & \text{or} & & 0.775 \text{ V} \\ & & & & \text{or} & & 1.291 \text{ mA} \end{aligned}$$

Since the dBm scale of this voltmeter is graduated in such dBm value (referenced to 1 mW, 600 Ω) as above, correction is required if other value is used for reference. Term "dBv" represents voltage ratio with 1 V as the reference value (0 dB). Due to the nature of logarithms, conversion can be accomplished simply through addition of a certain value to the meter reading. For the correction values, refer to Figs. 3-3 and 3-4.

(3) Decibel Conversion Chart

Fig. 3-3 shows a chart for converting ratios into decibels. The decibel value differs according to whether it is of a power ratio (or an equivalent) or it is of a voltage or current ratio.

Example 1: What dB is 5 mW with reference to 1 mW?

Since the ratio is of powers, the left hand scale must be used. Calculating $5\text{mW}/1\text{mW} = 5$, the dB value is known to be 7 dB (mW) as indicated by the dotted lines in the illustration.

Example 2: What are 50 mW and 500 mW in dB values with reference to 1 mW?

When the ratio is lower than 0.1 or higher than 10, decibel values must be calculated through addition or subtraction using the relationship shown in Table 3-3.

$$5 \text{ mW} = 5 \text{ mW} \times 10 = 7 + 10 = 17 \text{ dB}$$

$$500 \text{ mW} = 5 \text{ mW} \times 100 = 7 + 20 = 27 \text{ dB}$$

Table 3-3

Ratio	Decibel	
	Power ratio	Voltage or current ratio
10,000 = 1×10^4	40 dB	80 dB
1,000 = 1×10^3	30 dB	60 dB
100 = 1×10^2	20 dB	40 dB
10 = 1×10^1	10 dB	20 dB
1 = 1×10^0	0 dB	0 dB
0.1 = 1×10^{-1}	-10 dB	-20 dB
0.01 = 1×10^{-2}	-20 dB	-40 dB
0.001 = 1×10^{-3}	-30 dB	-60 dB
0.0001 = 1×10^{-4}	-40 dB	-80 dB

Example 3: What is 15 mV in dB(V) value?

Since this decibel is referenced to 1 V calculate at first as $15\text{mV}/1\text{V} = 0.015$. Next, using the voltage/current scale, calculate as

$$0.015 = 1.5 \times 0.01 = 3.5 \times 0.01 = 3.5 + (-40) = -36.5 \text{ dB(V)}$$

or in the reverse as $1\text{V}/15\text{mV} = 66.7$.

$$66.7 = 6.67 \times 10 \rightarrow 16.5 + 20 = 36.5 \text{ dB(V)}$$

$$\therefore -36.5 \text{ dB(V)}$$

(4) Decibel Addition Chart

Fig. 3-4 shows an addition chart which is used when calculating the power from the dBm value determined by this meter.

Example 1: The voltage across the voice coil (8 Ω) of a speaker was measured with this meter and the reading was -4.8 dBm. What was the power (apparent power) being sent to the speaker?

Referring to Fig. 3-4. the value to be added is determined to be +18.8 as indicated with the dotted line in Fig. 3-4. The power level can be known by adding this value to the reading as follows:

$$\text{dB (mW, } 8\Omega) = -4.8 + 18.8 = +14$$

The value of 14 dB (mW, 8 Ω) can be converted referring to Fig. 3-3 as 14 dB (mW, 8 Ω) \rightarrow 25 mW.

Example 2: What voltage (V) is required to feed a power of 1 W to a load of 10 k Ω ?

Since 1 W is 1000 mW or 30 dB (mW), a voltage which will give 30 dB (mW, 10k Ω) should be calculated. Referring to Fig. 3-4, the value to be added for 600 Ω \rightarrow 10 k Ω is known to be -12.2. Therefore, the indication of this meter should be $30 - (-12.2) = 42.2$ on the dB (mW, 600 Ω) scale. The required voltage is such that it causes a deflection of $42.2 - 40 = 2.2$ dBm on the 40 dB range (0 ~ 100 V). This value is found to be 42.2 dBm = 100 V.

4. OPERATING PRINCIPLE

Models 1633B and 1653B AC Voltmeters consists of an input circuit, preamplifier, meter driver, output circuit, and power supply as shown in Fig. 4-1.

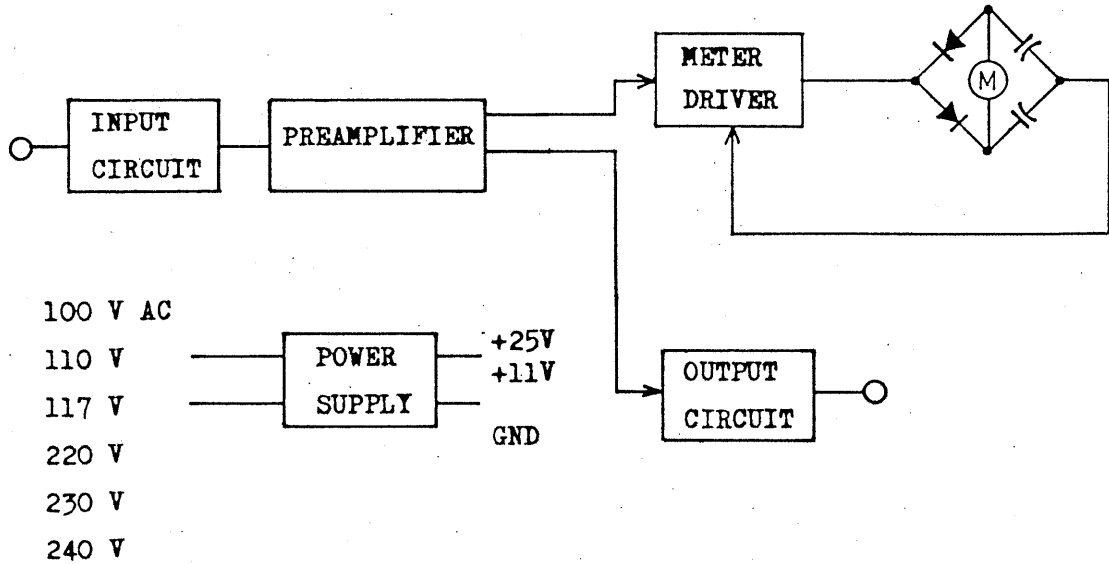

Fig. 4-1

4.1 Input Circuit

The input circuit consists of a 1st-stage attenuator (0/60 dB), an impedance converter, and a 2nd-stage 10 dB-step 6-range attenuator (0/10/20/30/40/50 dB) as shown in Fig. 4-2.

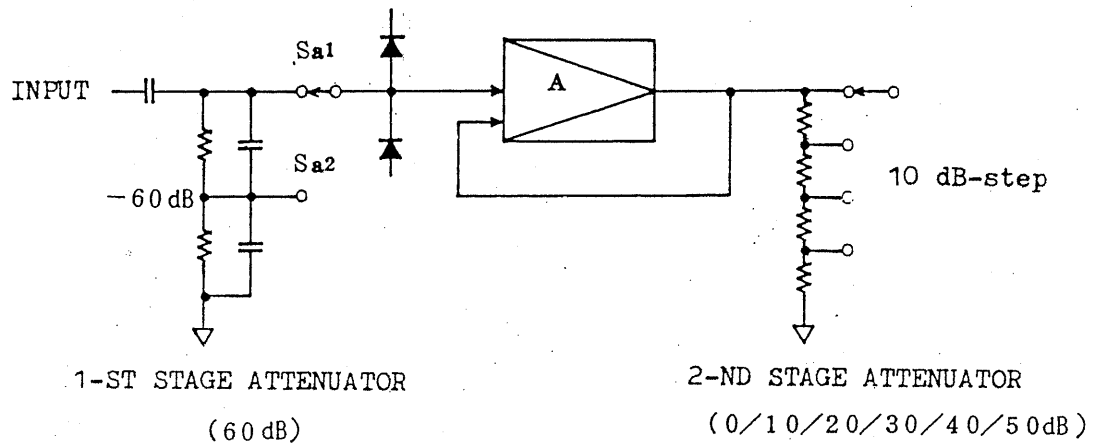

Fig. 4-2

The input signal is fed through Sl_a when the range switch is in a position of 300 μ V ~ 100 mV (500 μ V ~ 150 mV for the 1653B) or through Sl_b when the range switch is in a position of 300 mV ~ 100 V (500 mV ~ 150 V for the 1653B). After being attenuated as required, the input signal is fed to the impedance converter which has FET transistors Q201 and Q202 for the initial stage and which provides a high input impedance and a low output impedance. Then the signal is fed to the 2nd-stage attenuator which attenuates the signal level to approximately 300 μ V (500 μ V for the 1653B). Diodes CR201 and CR202 are for protection against overvoltage input.

4.2 Preamplifier

The preamplifier amplifies the low level signal received from the input circuit. It is a negative feedback amplifier consisting of three transistors.

4.3 Meter Driver

The indicating meter driver circuit has transistors Q305 and Q306. The signal is fed from the collector of Q306 to the emitter of Q305 through a current feedback circuit (rectifier diodes).

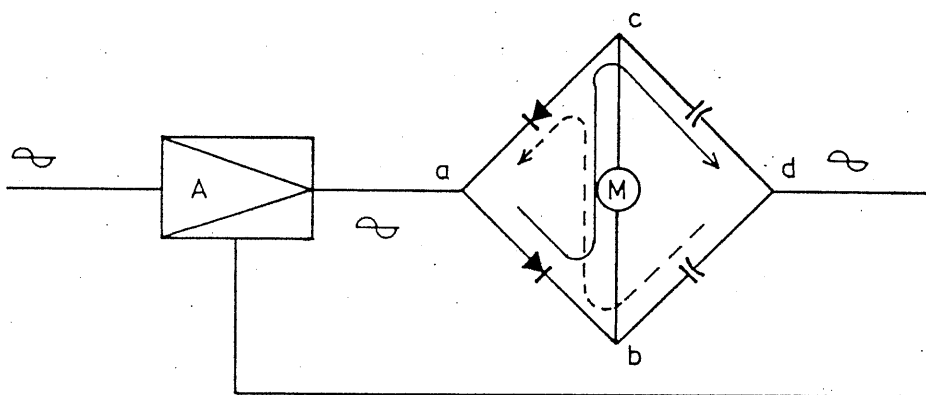

Fig. 4-3

793700

Due to the above, the diodes operate with a current almost constant, thereby improving their linearity and providing a linear scale. Fig. 4-3 illustrates this function. The current for the positive cycles of the amplifier output voltage flows a b c d and that for the negative cycles flows d b c a. The indicating meter deflects the mean value of this current.

4.4 Output Circuit

The collector voltage of transistor 302 of the preamplifier is amplified by transistor Q304 and the amplified signal is delivered for an external use. The output terminal voltage is about 1 V (about 1.5 V for the 1653B) rms when the indicating meter is deflected to the full scale.

4.5 Power Supply

The power supply circuit has two constant-voltage circuits for +11 V supply and +25 V supply. The +25 V constant-voltage circuit has zener diode CR103 which provides a reference voltage, transistor Q102 which amplifies the error voltage, and transistor Q101 which controls the voltage in series in order to provide the constant voltage supply. The +11 V constant-voltage supply is derived from the reference voltage.

5. MAINTENANCE

5.1 Inspection of Internal Components

To gain access to the internal components, remove the casing after removing two clamping-screws at each of the top and lower sections of right and left panels. The layout is shown in Fig. 5-1.

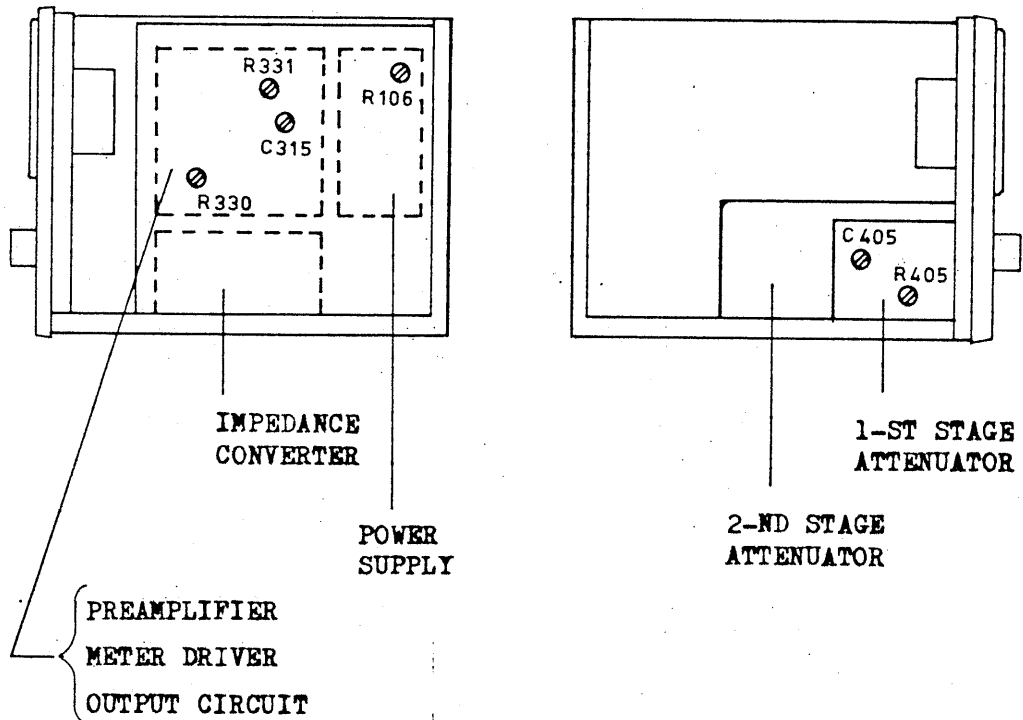

Fig. 5-1

793702

5.2 Adjustment and Calibration

When the meter is found that it does not satisfies the performance specification after a long period of use or after repair, adjust and calibrate the meter as follows:

(1) Adjustment of Constant-voltage Circuit

Connect a DC voltmeter between the emitter of transistor Q101 of power supply circuit and the ground. So adjust potentiometer R106 that the voltmeter reads +25 V.

(2) Calibration for High and Low Frequency Ranges (Preamplifier)

Before calibrating the meter, perform ZERO adjustment of the meter as explained in Par. 3.2 (2). Then, proceed as follows:

Set the range switch in the 10 mV position. Apply a calibration voltage (a sinusoidal waveform of low distortion) of 10 mV, 400 Hz to the input terminal. So adjust potentiometer R331 of the preamplifier that the meter pointer deflects accurately to the full scale position. (Use a 15 mV input and the 15 mV range for the 1653B.)

Next, set the calibration signal frequency at 1 MHz. Adjust trimmer capacitor C315 in the same manner as above.

(3) Adjustment of 1st-stage Attenuator

Set the RANGE switch in the 300 mV position. Apply a calibration signal of 300 mV, 400 Hz to the input terminal. So adjust potentiometer R405 of the attenuator that the meter pointer deflects to the full scale position.

Next, set the calibration signal frequency at 40 kHz. Adjust trimmer capacitor C405 in the same manner as above. (Use a 500 mV input and the 500 mV range for the 1653B.)

Repeat alternately the above adjustment procedures at 400 Hz and 40 kHz for several times or until both conditions are satisfied at the same time.

(4) Adjustment of Output Amplifier

Set the range switch in the 1V position. Apply a calibration signal of 1 V, 400 Hz to the input terminal. So adjust potentiometer R330 that the voltage delivered to the output terminal is made 1 V. (For the 1653B, use a 1.5 V input and the 1.5 V range and so adjust the potentiometer that the output voltage is made 1.5 V.)

5.3 Troubleshooting

The meter is manufactured under stringent quality control and should be free of troubles. However, when it has failed due to aging or other cause, check it referring to the circuit voltage charts given in this section. The normal circuit voltages are shown in Tables 5-1, 5-2, and 5-3. These voltages are as measured with reference to the ground using a Kikusui Series 107 Voltmeter, the input impedance of which is 11 MΩ.

(1) Impedance Converter

Table 5-1

Transistor	Emitter source (V)	Base gate (V)	Collector drain (V)
Q201 2SK117	7.2		21
Q202 2SC945	6.6	7.2	25

(2) Preamplifier, Meter Driver, and Output Circuit

Table 5-2

Transistor	Emitter (V)	Base (V)	Collector (V)
Q301 2SC372			4.6
Q302 2SC372	5.4	6	9.7
Q303 2SA495	5.4	4.6	2.7
Q304 2SC945	9.8	10.4	21
Q305 2SC945			5
Q306 2SC945	4.4	5	8

(3) Power Supply

Table 5-3

Transistor	Emitter cathode (V)	Base anode (V)	Collector (V)
Q101 2SC1124 or 2SD381	25	25.6	46
Q102 2SC372 or 2SC945	11	11.6	25.6
CR104 EQA01-07S or RD6.8JB	33	25	
CR103 RD11E or RD11A	11	0	

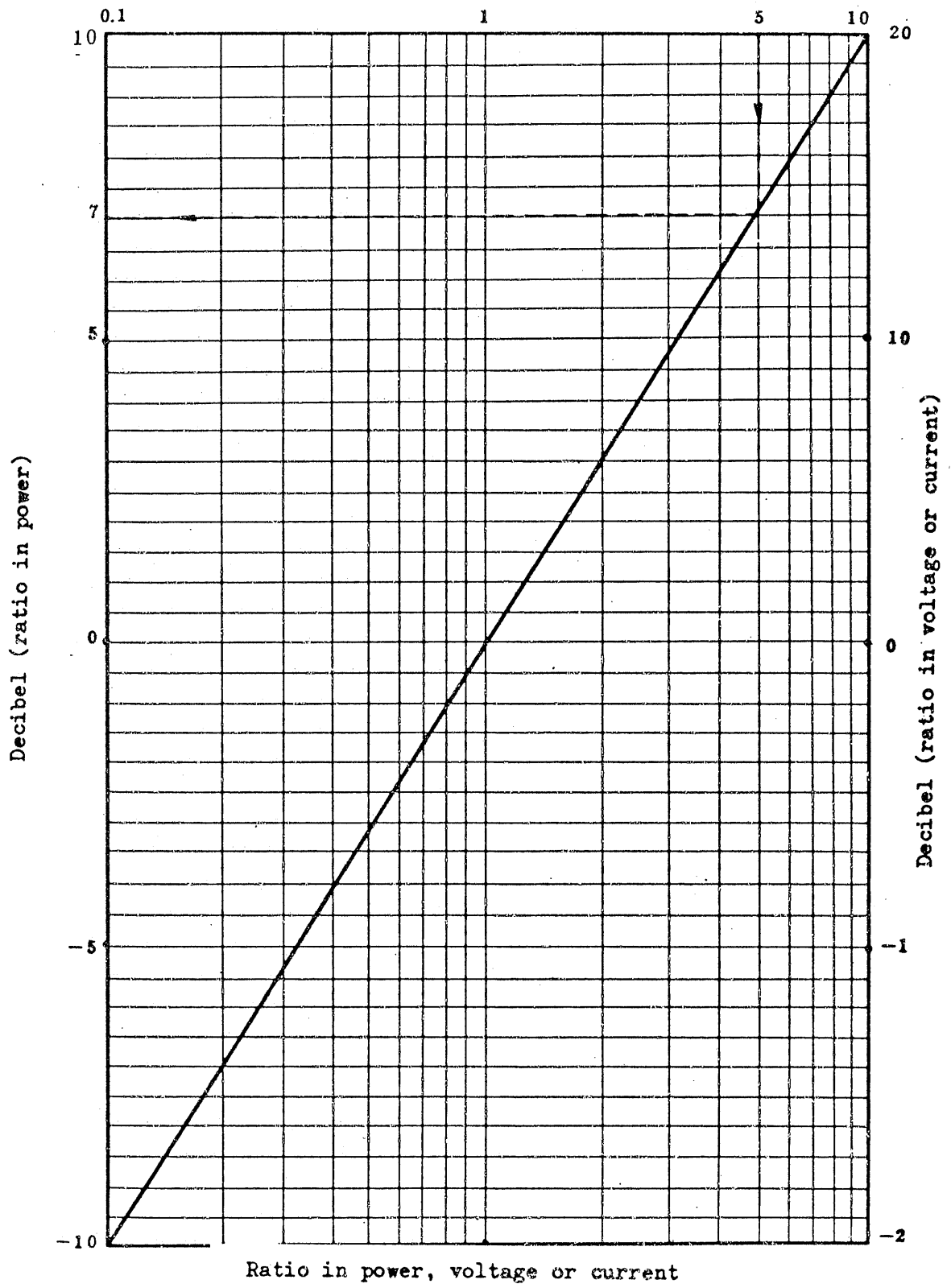

Decibel conversion chart

Fig. 3-3

752101

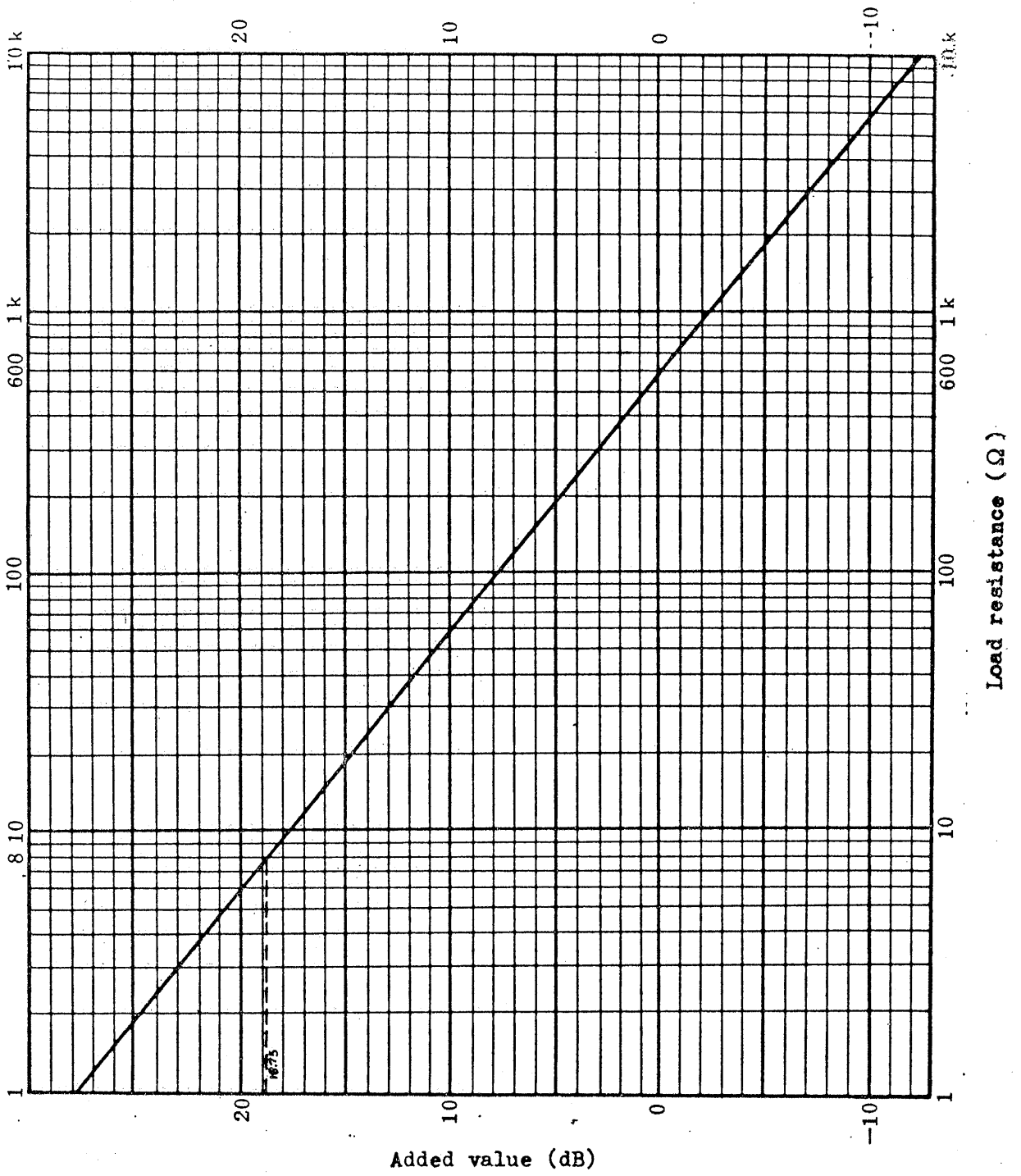

Decibel addition chart

Fig. 3-4

798701